



Features

- Used to determine the air quality, based on a mixed gas sensor (VOC sensor)
- To measure the air quality in offices, hotels, meeting rooms, convention centres, schools, airports, apartments, stores, restaurants etc.
- 0-10 Vdc or 4-20 mA or 0-20 mA output (selectable)
 - 0-10 Vdc: 0 Vdc = clean air 10 Vdc = polluted air
 - 4-20 mA: 4 mA= clean air, 20 mA = polluted air
 - 0-20 mA: 0 mA= clean air, 20 mA = polluted air

Traffic light indication for QRT SL and QRT SLP

LED	VOC- fractions	Output (U) approx.	Output (I) approx.
Green 1	Alright	0 to 3.9 V	4.0 to 10.2 mA
Green 2	Alright	4. to 5.9 V	10.3 to 13.4 mA
Yellow	Increased	6. to 7.9 V	13.5 to 16.1 mA
Red 1	Too high	8. to 9.9 V	16.2 to 19.8 mA
Red 2	Too high	> 9.9 V	> 19.9 mA

Ordering

Type no.	Description
Air Quality transmitter (VOC) for Room Mounting	
QRT	standard version
QRT S	Same as QRT and with changeover contact
QRT SL	Same as QRT and with changeover contact and with "traffic light" 5 coloured LED's indication of air quality (VOC)
QRT SLP	Same as QRT and with changeover contact and with "traffic light" 5 coloured LED's indication of air quality (VOC) and with Potentiometer
QRT SS	Same as standard version QRT but with stainless steel enclosure

Technical data

Sensor	VOC sensor (metal oxide) with automatic self-calibration	Detectable gases	
Measuring range	0-100% air quality referred to calibration gas multi-range switching (selectable via DP-switches) VOC: Low-Medium-High	<ul style="list-style-type: none"> • Cigarette smoke • Automobile exhaust • Breath air • Carbon dioxide (CO₂) • Carbon monoxide (CO) • Solvent fumes • Alcohol fumes • Acetone • Acrylonitrile • Ammonia • Benzene • Chlorine • Dimethyl amine • Ethane • Ethylene • Ethylene oxide • Formaldehyde • Hydrogen 	<ul style="list-style-type: none"> • Hydrogen sulfide • Isobutane • Methane • Methanol • Methyl chloride • Methylene chloride • Methy ether • Methyl acetate • Methyl ethyl ketone • n-Hexane 2 • n-Petane • Propane • R-11 • R-12 • R-502 • R-123 • Sulfur dioxide • Vinyl chloride
Measuring accuracy	+/- 20% of final value (referred to calibration gas)		
Power supply	24 Vac/dc		
Current consumption	ca. 70 mA at 24V		
Output(s)	0-10 Vdc, 4-20 mA or 0-20 mA (selectable)		
Switch output (optional)	potential-free changeover contact (24V) switch point adjustable from 0-100% of output signal.	Applications:	
Ambient temp. range	0 to +50°C		<ul style="list-style-type: none"> - For air quality measurement in offices, hotels, meeting rooms and convention centres, apartments, stores, restaurants, etc. - For quantitative evaluation of room air pollution with contaminating gases (cigarette smoke, body perspiration, exhaled breathing air solvent vapours, emissions from building members and cleaning agents) - For adjustable sensitivity regarding the maximum air contamination to be expected. - For room ventilation as-needed, enabled by air changes only taking place when air is polluted while conserving energy at the same time.
Detection of gases	not selective		
Service life	> 60 months (under normal load conditions)		
Long-term stability	<1% of final value per year		
Warm-up period	1 hour		
Response time	< 60 sec.		
Housing material	Plastic		
Protection	IP 30		

Description

The self-calibrating microprocessor-controlled room air quality transmitter QRT used to determine the room air quality on basis of a mixed gas sensor / VOC sensor (VOC = Volatile Organic Compounds).

Room air quality is understood as subjective air quality felt by human beings with their olfactory organs.

As perception varies from person to person and therefore, air quality is assessed differently, a general definition of criteria for room air quality is not possible.

By linearising and high operating temperatures, the air quality transmitter achieves marginal drift and good stability.

The sensor is automatically self-calibrating.

The air quality sensor does not trace the concentrations of individual gases, but assesses the mixed gas as such, i.e. gas concentrations are not measured selectively

Therefore, it is not possible to specify gas concentrations by the unit ppm.

Detectable gases: mixed gas, vapours of alcohols, cigarette smoke, automobile exhaust gases, exhaled breathing air, combustion smoke (from wood, paper, plastics).

In addition, compounds of alkanes, alkenes, aromats, terpenes, halogenated hydrocarbons, esters, aldehydes and ketones as well as native VOCs such as terpenes and isoprene are ranking among volatile organic compounds VOC.

VOCs also evaporate from chemical products used in construction such as coating compounds, adhesives, or sealing compounds, furnishing objects, cleaning and care products, office chemicals and floor carpeting.

The sensor's service life is depending on the type of burden and gas concentration and is more than 60 months under normal load conditions.

The new design implies the alternative to choose between three sensibility ranges by means of DIP switches, comparable to three measuring ranges: LOW for low, MEDIUM (default, equivalent to the hitherto existing type of this device) for medium, and HIGH for high noxious gas contaminations.

Dimensions in mm for ABS plastic housing

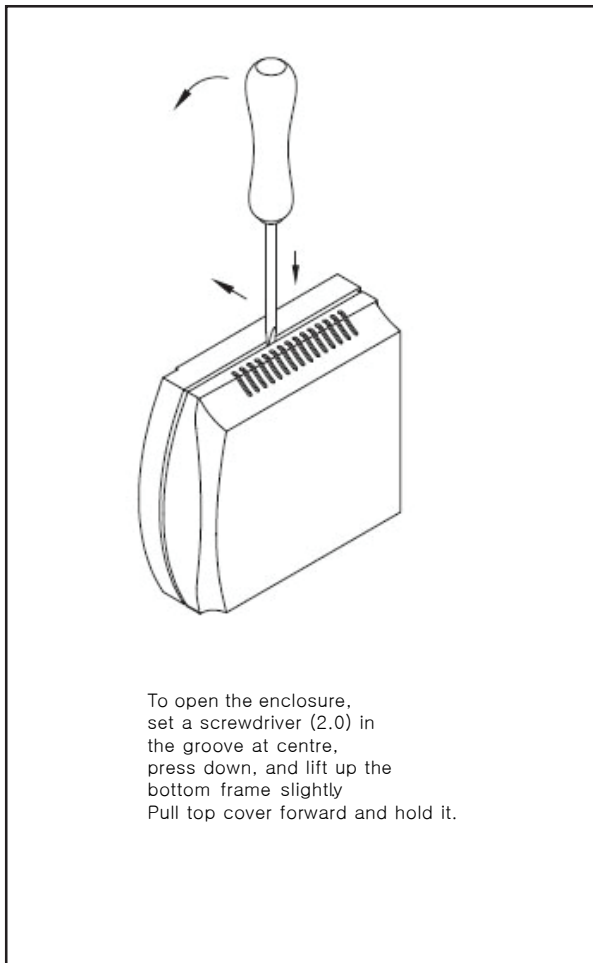
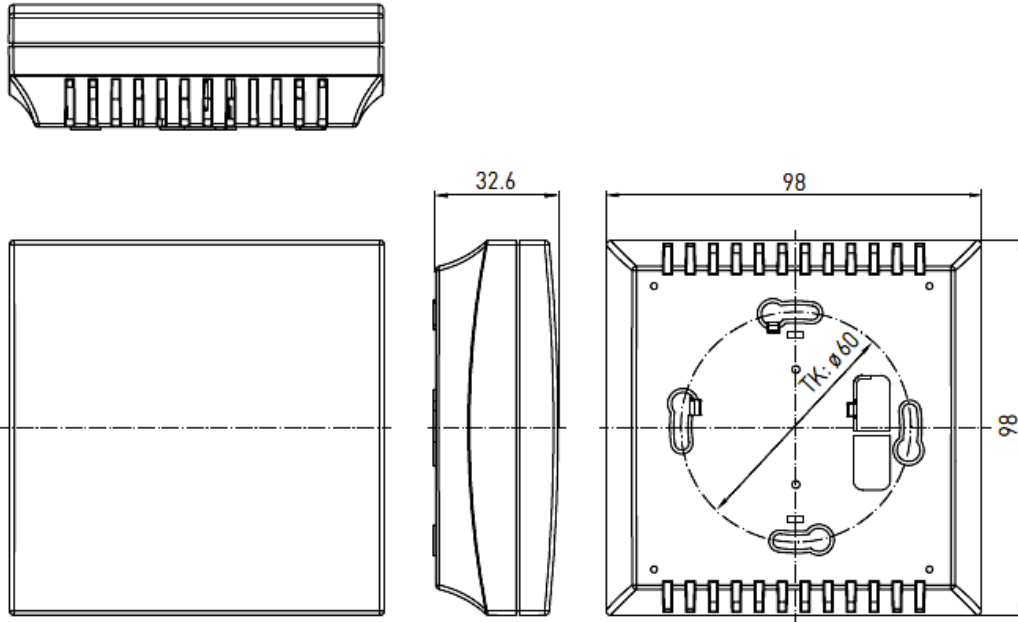

Dimensions in mm for stainless steel housing

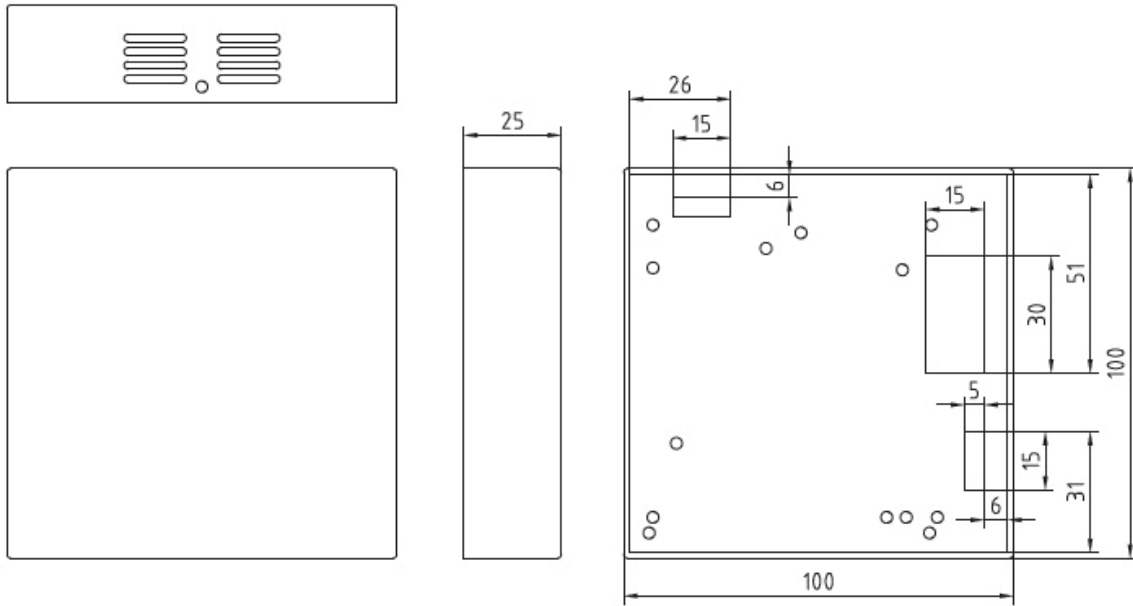

Electrical connections

QRT and QRT SS

1	- GND
2	+ Power supply 24 V _{ac/dc}
3	GND
4	Output 0-10 Vdc, 4-20 mA or 0-20 mA

QRT S, QRT SL and QRT SLP



1	- GND
2	+ Power supply 24 V _{ac/dc}
3	GND
4	Output 0-10 Vdc, 4-20 mA or 0-20 mA
5	Normally open
6	contact
7	Breaker





Multi-range switching

VOC (sensitivity adjustable)	DIP 1	DIP 2	DIP 3
VOC LOW	ON	OFF	OFF
VOC MEDIUM (default)	OFF	ON	OFF
VOC HIGH	OFF	OFF	ON
VOC Calibration mode			DIP 4
Automatic self-calibration	OFF		
Manual calibration	ON		
Output selection			DIP 5
Output 0...20 mA	OFF		
Output 4...20 mA	ON		

Schematic diagram

-  Pushbutton manual calibration air quality
-  LED calibration

Selection output:

-  Voltage (V), default
-  Current (mA)

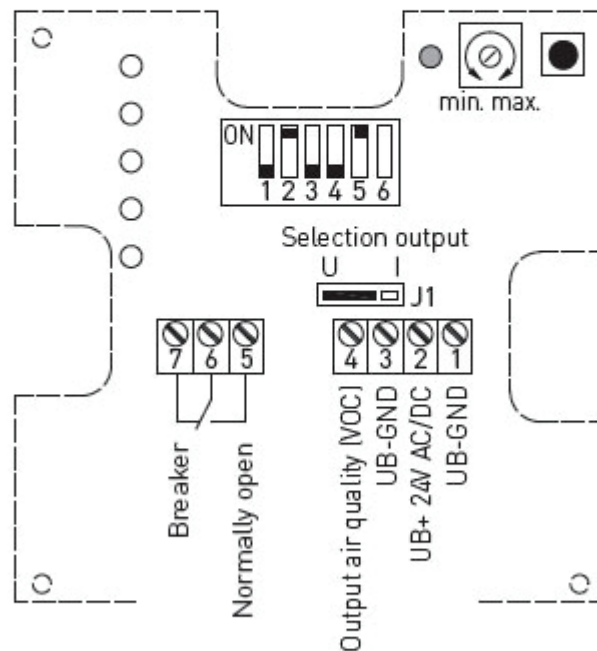

GND terminals (1) and (3)
are connected on the circuit board.
DIP switch (6) is not assigned!

Note:

This air quality sensor must not be used as a safety-relevant device.

Notes regarding QRT

- This device may only be used in non-precipitating air without above-atmospheric or below-atmospheric pressure at the sensor element.
- In the operating mode with current output, the device delivers an output current of either 0...20 mA or 4...20 mA (selectable via jumper). This device is not a transmitter.
- The voltage output is short-circuit proof.
- Applying overvoltage will destroy the device.
- In case of pollution, we recommend cleaning and recalibration in the factory
- The air quality signal "good"..."bad" is represented by the output signal 0...10 V
- The device operating range covers 10...95 % relative humidity respectively 0...50 °C. Beyond that range, mismeasurements or increased deviations will occur.
- The chemical sensor is a consumable. The lifetime of the sensor depends on nature and concentration of the pollutant gas burden.
- If this device is operated beyond the specified range, all warranty claims are forfeited.

Air quality is measured through a VOC sensor (metal oxide). Due to its functional principle, the lifetime of the sensor depends on nature and concentration of the pollutant gas burden.

The sensitive layer of the sensor element reacts with all volatile organic compounds and is thereby modified in its electrical properties or "exhausted". This process results in a displacement of the characteristic curve. Such characteristic curve displacement however amounts to less than 15 % / year under normal burden. In measuring air quality the general condition of air quality is detected. Whether air quality is "good" or "bad" is differently interpreted by each person.

Different pollution burdens and concentrations influence the air quality signal (0...10 Volt) in different ways. Examples for this are cigarette smoke, deodorant sprays, cleaning agents, or also various adhesive materials for floor and wall coverings as well as dyestuffs. Increased burdens e.g. by solvents, nicotine, hydrocarbons, aerosol propellants etc. intensify consumption and aging of the sensor element. Particularly under high pollutant gas burdens – also during non-operational idle state periods of the devices (transport and storage) – zero-point drift will occur. Consequently this must be corrected at site according to the respective circumstances or basic burdens.

Air quality measuring instruments of different manufacturers cannot directly be compared because of different functional principles, preset basic burdens (zero-point), and permitted burdens (amplification / sensitivity). Devices are preset respectively calibrated according to the sensor manufacturer's specifications. Here, a zero-point and a final value is determined and thus a maximum burden. In particular cases, exceeding measuring ranges or excessive basic burdens on the devices will occur (outgassing floor carpeting, wall paint, etc.). In order to enable distinguishing different air qualities, devices need to be adjusted by the customer according to the conditions existing on site that do not correlate to the factory-preset definition range and calibration. Please note that factory calibration is thereby lost and compliance with technical data can no longer be guaranteed.

Automatic calibration of air quality (default), except for UP

The minimum initial value for air quality is memorized within a period of ca. 4 weeks. After that period has lapsed, the output signal is standardised to zero-point (1.0 V). The maximum amount of correction is thereby limited to 1 V D interval. In this way long-term drifts and operational aging effects of the sensor element are completely eliminated.

Manual calibration of air quality , except for UP

Manual calibration can be started independently from the position of jumper J3 by pushing the button. After connecting the device, a period of at least 2 hours of continuous operation of the device at „normal“ air quality is to be ensured. Manual calibration of the output signal to 1 V (zero-point) is started by pressing the button „Manual calibration“ (for ca. 5 seconds). Preparing for calibration is indicated by a blinking LED. Setting the output to 1 V at actual ambient conditions follows automatically thereafter. During this phase, the LED is permanently activated. After calibration is completed, the LED is deactivated.

Putting in operation

Upon energizing the device, a self-test and tempering takes place. Depending on ambient conditions, this process takes 3 to 5 minutes. During that time, the output analog voltage deviates from the actual measured value.

We reserve the right to make changes in our products without any notice which may effect the accuracy of the information contained in this leaflet.

Supply Voltage

For operating voltage reverse polarity protection, a one-way rectifier or reverse polarity protection diode is integrated in this device variant. This internal one-way rectifier also allows operating 0-10 Vdc devices on AC supply voltage.

The output signal is to be tapped by a measuring instrument. Output voltage is measured here against zero potential (0 V) of the input voltage!

When this device is operated on DC supply voltage, the operating voltage input UB+ is to be used for 15 to 36 V DC supply and UB- or GND for ground wire!

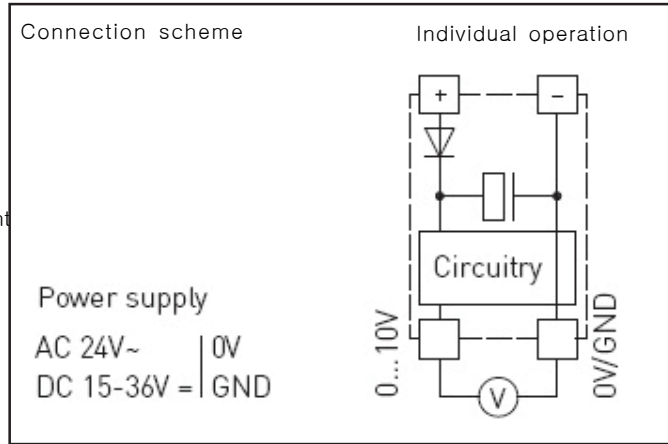

When several devices are supplied by one 24 V AC voltage supply, it is to be ensured that all "positive" operating voltage input terminals (+) of the field devices are connected with each other and all "negative" operating voltage input terminals (-) (= reference potential) are connected together (in-phase connection of field devices). All outputs of field devices must be referenced to the same potential!

In case of reversed polarity at one field device, a supply voltage short-circuit would be caused by that device. The consequential short-circuit current flowing through this field device may cause damage to it.

Therefore, pay attention to correct wiring!

